

PRODUCT TECHNICAL BULLETIN 36425

REMOTE OIL FILTER MOUNT FAILURE

Date:	24/01/2025
Issue:	A
Prepared for:	industry
Applicable machines:	MineCruiser Mk7/ Mk8 Predator / Grader (less exposed)
Part numbers:	7-055413-700 Remote Oil Filter Assembly/ 7-221493-700 / 7-056559-700 (grader option)

Background:

A recent incident occurred on a MineCruiser Mk7, whereby the fasteners retaining the remote filter head had loosened, causing the filter to drop into the transmission tunnel and for the hoses to rub on the driveshaft. This eventually resulted in hose failure and a loss of oil supply to the engine. Despite the low oil alarm activating, engine damage still resulted from operation during the 10 second override period.

Communication:

On further investigation, some issues were identified with the fastening method of the remote oil filter head. A slight mismatch had occurred between the size of the washers, resulting in only a small amount of surface area contact pressure onto the remote oil filter bracket. Also, anti-seize had been used on installation. Although not necessarily a cause of the bolts losing tension, anti-seize provides no retaining properties.

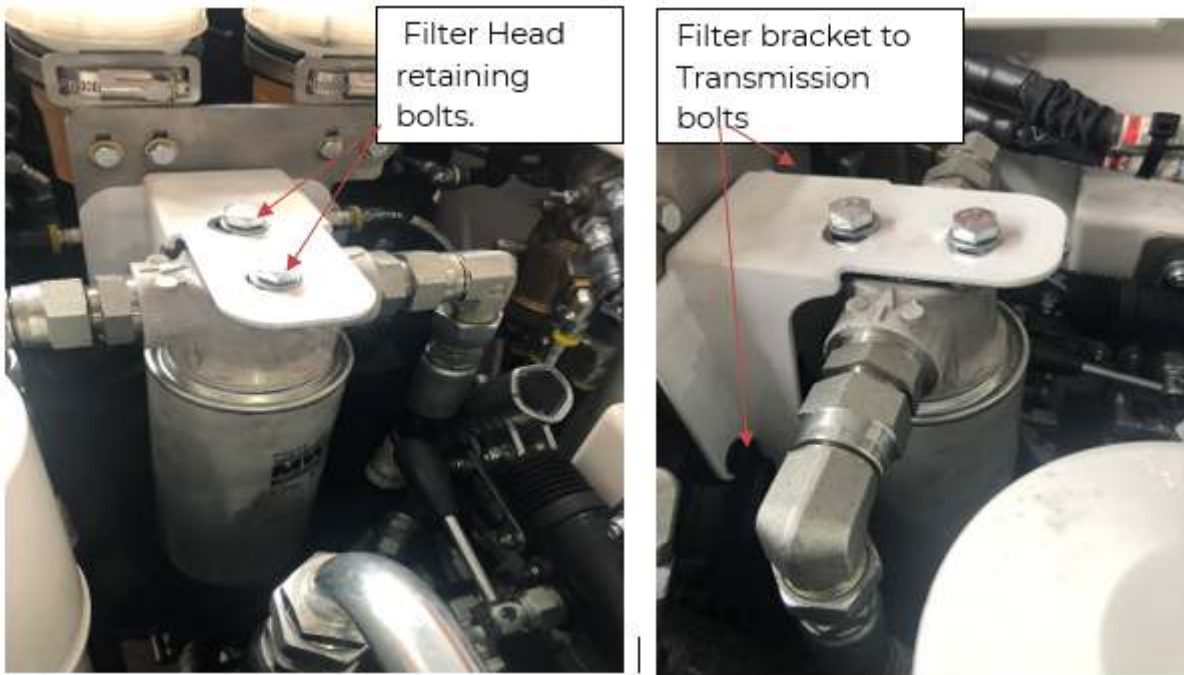

Remote oil filter bracket – fastener locations

Recommendations:

The following recommendations are provided for fastening the remote oil filter bracket. Inspect remote oil filters to ensure they are secure.

Remote oil filter head to bracket

- Bolts M10 x 25Lg Zn Hex Head Course Thread Class 8.8
- Disc lock washers to be fitted.
- Apply thread locker Loctite 243 or equivalent.
- Torque bolts to 35Nm.

Remote oil filter bracket to transmission

- Bolts 7/16 UNC x 2 1/4" Lg Hex Head Class 5
- Disc lock washers to be fitted.
- Apply thread locker Loctite 243 or equivalent.
- Torque bolts to 52Nm.

Additionally, a locking tab has also been added as an optional locking method for the filter head fasteners and is included in update assembly for the remote oil filter 7-055413-700 / 7-221493-700. Note: these assemblies can also be used on the grader and predator, although not in the vicinity of rotating components, they should also be inspected for security.

Please distribute this bulletin to all relevant personnel

Cougar contacts in respect to this bulletin:

Operations Manager
 Compliance and Business Improvement
 Product Support QLD
 Product support NSW
 Product support south coast NSW
 Spare Parts Manager

Garrad Latham 0407 272 296
 Bill Davidson 0409562 385
 Mick Ruhl 0428 561237
 Josh Preece 0419880414
 Cameron Pike 0428628944
 Greg Davies 0422 025 295
greg.davies@cougarme.com.au

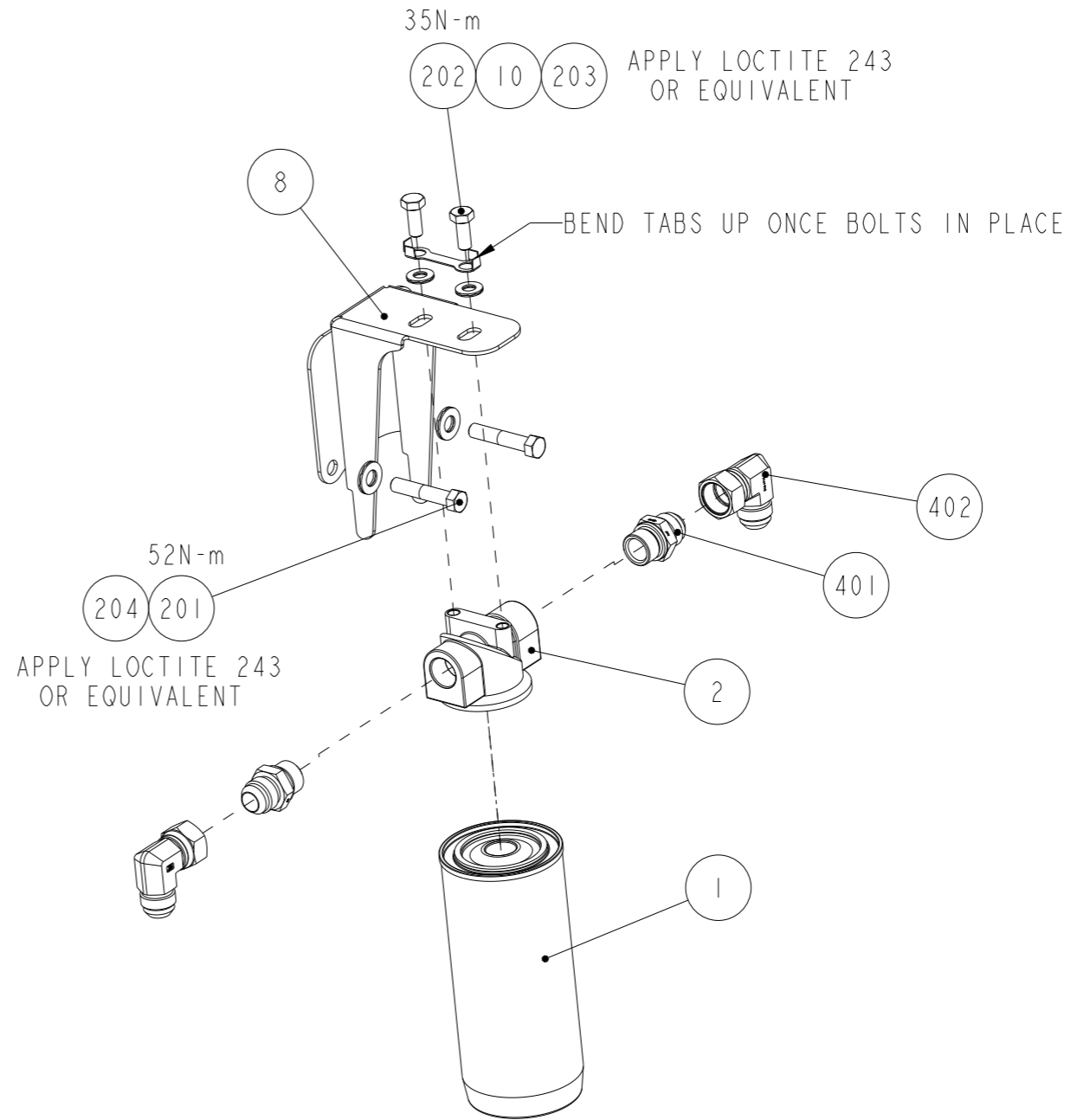
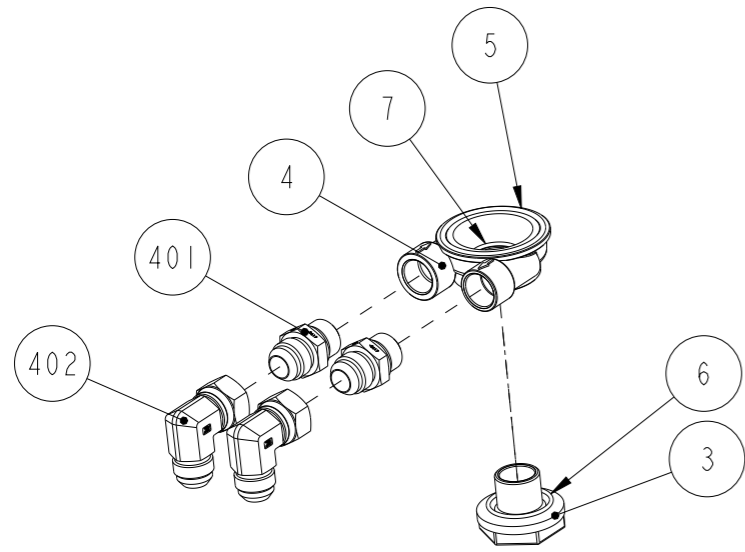

REV.	DATE	DESCRIPTION	DRAWN	CHECK.
B	6/09/2024	BOLT LOCKING PLATE ADDED, UPDATED FASTENERS, TORQUE SPECS ADDED AS PER DCN-21283	AJ	TPM
A	24/03/15	ISSUED FOR MANUFACTURE	JMM	

DO NOT SCALE
IF IN DOUBT, ASK

UNINDICATED TOLERANCES TO ISO 286-2:
JS12 FOR MACHINING, JS14 FOR FABRICATION & ± 0.5° FOR ANGLE

⊥: PERPENDICULAR	⊙: CONCENTRICITY
//: PARALLELISM	▭: FLATNESS
	-: STRAIGHT
	⊖: MAX. MATERIAL CONDITION.

THIS DRAWING IS STRICTLY CONFIDENTIAL AND MUST NOT BE COPIED, REPRODUCED, MANUFACTURED OR SUPPLIED FROM WITHOUT PERMISSION OF COUGAR MINING EQUIPMENT

CHECK CME'S ORDER MATCHES THIS DRAWING NUMBER AND REVISION BEFORE MANUFACTURE



	DRAWN	CHECKED	APPROVED
NAME	JMM	MAS	<i>L. MORRIS</i>
DATE	24/03/15	24/03/15	20/09/2024
SCALES	1:5		
	A3		

REMOTE OIL FILTER
MK7 MINECRUISER
SHEET 1 OF 1

DRG. No.
7-055413-700

REV.
B

PARTS LIST

Drawing No: 7-055413-700

Description: Remote Filter Assy MWM C/W O-Rings Head Adaptor & Elem MK7 Minecruiser

Revision No: B

Date Approved: 6/09/2024

Line No	Code	Rev	Description:	Unit	Quantity
1	7-054011-710	-	Oil filter MWM engine 4.10TC	Each	1
2	7-055367-700	A	Remote Filter Head MWM	Each	1
3	7-055368-700	-	Hollow Screw Remote Oil Filter MWM	Each	1
4	7-055369-700	-	Adaptor Engine Remote Filter MWM	Each	1
5	7-055370-700	-	O-Ring Adaptor Remote Oil Filter	Each	1
6	7-055371-700	-	O-Ring Adaptor Remote Oil Filter	Each	1
7	7-055372-700	-	O-Ring Adaptor Remote Oil Filter	Each	1
8	7-055414-700	B	BracketRemote Eng. Oil Filter Minecruiser MK7 MWM	Each	1
9	7-180305-713	-	Remote Oil Filter Hose 1650Lg MK7 Minecruiser	Each	2
10	7-194186-700	A	Oil Filter Bolt Locking Plate	Each	1
200	7-610502-700	A	FASTENER KIT REMOTE OIL FILTER MK7	Each	1
401	7-187109-712	-	Nipple M26M-17JICm	Each	4
402	7-187228-710	-	Elbow 90 17JICm-17JICfsw	Each	4

PARTS LIST



Drawing No: 7-610502-700

Description: FASTENER KIT REMOTE OIL FILTER MK7

Revision No: A

Date Approved: 8/10/2024

Line No	Code	Rev	Description:	Unit	Quantity
201	B716CX2148Z		7/16 UNC X 2-1/4 GR.8 Z/P HEX HD BOLT	Each	2
202	BM10X2588Z		M10 X 25 8.8 Z/P HEX HD BOLT	Each	2
203	WDLM10HSZ	-	WASHER DISC-LOCK M10 Z/P	Each	2
204	WDLM12HSZ	-	WASHER DISC-LOCK M12 Z/P	Each	2

1 2 3 4 5 6 7 8 9 10 11 12

A
B
C
D
E
F
G
H

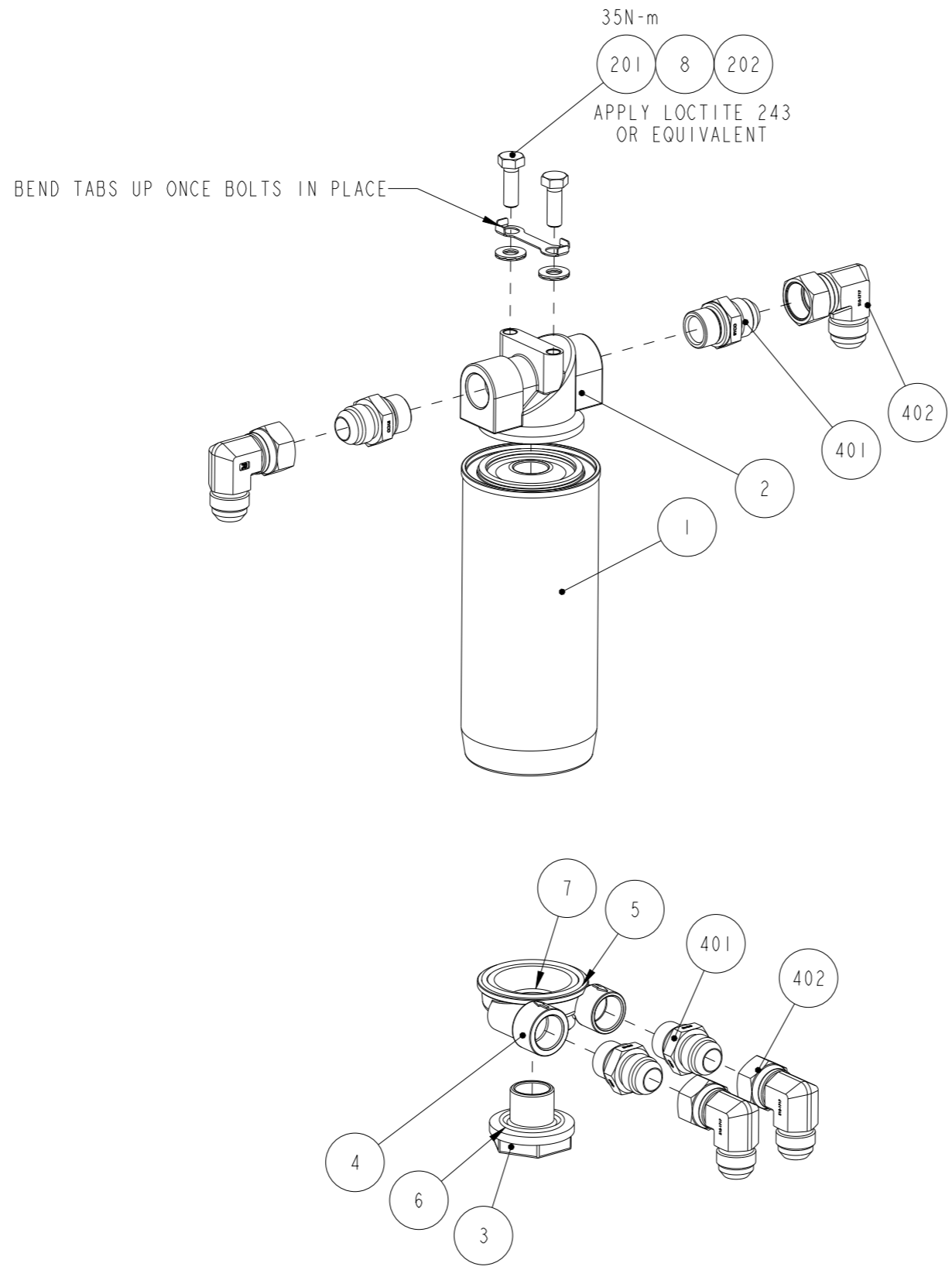

REV.	DATE	DESCRIPTION	DRAWN	CHECK.
B	8/10/2024	UPDATED TO CREO, LOCKING PLATE ADDED	AJ	MR
A	8/01/19	INITIAL RELEASED	DB	WSD

DO NOT SCALE
IF IN DOUBT, ASK
UNINDICATED TOLERANCES TO ISO 286-2:
JS12 FOR MACHINING, JS14 FOR FABRICATION & ± 0.5° FOR ANGLE

⊥: PERPENDICULAR
//: PARALLELISM
⊙: CONCENTRICITY
▭: FLATNESS
—: STRAIGHT
⊖: MAX. MATERIAL CONDITION

THIS DRAWING IS STRICTLY CONFIDENTIAL AND MUST NOT BE COPIED, REPRODUCED, MANUFACTURED OR SUPPLIED FROM WITHOUT PERMISSION OF COUGAR MINING EQUIPMENT
CHECK CME'S ORDER MATCHES THIS DRAWING NUMBER AND REVISION BEFORE MANUFACTURE



	DRAWN	CHECKED	APPROVED
NAME	DB	WSD	<i>G. MORRIS</i>
DATE	08/01/2019	08/01/2019	10/10/2024
SCALES	1:4		
A3	A3		

REMOTE OIL FILTER
PREDATOR
SHEET 1 OF 1

DRG. No. **7-221493-700** REV. **B**

1 2 3 4 5 6 7 8 9 10 11 12

PARTS LIST

Drawing No: 7-221493-700

Description: REMOTE OIL FILTER ASSEMBLY

Revision No: B

Date Approved: 8/10/2024

Line No	Code	Rev	Description:	Unit	Quantity
1	7-054011-710	-	Oil filter MWM engine 4.10TC	Each	1
2	7-055367-700	A	Remote Filter Head MWM	Each	1
3	7-055368-700	-	Hollow Screw Remote Oil Filter MWM	Each	1
4	7-055369-700	-	Adaptor Engine Remote Filter MWM	Each	1
5	7-055370-700	-	O-Ring Adaptor Remote Oil Filter	Each	1
6	7-055371-700	-	O-Ring Adaptor Remote Oil Filter	Each	1
7	7-055372-700	-	O-Ring Adaptor Remote Oil Filter	Each	1
8	7-194186-700	A	Oil Filter Bolt Locking Plate	Each	1
201	BM10X3088Z		M10 X 30 8.8 Z/P HEX HD BOLT	Each	2
202	WDLM10HSZ	-	WASHER DISC-LOCK M10 Z/P	Each	2
401	7-187109-712	-	Nipple M26M-17JICm	Each	4
402	7-187228-710	-	Elbow 90 17JICm-17JICfsw	Each	4