



**PRODUCT TECHNICAL BULLETIN 35852:
MAXIMUM SERVICE BRAKE PRESSURE SETTING
MINECRUISER MK 6.0 & MK 7.0**

APPLICABLE DESIGN REGISTRATION: MDR 095324 (-1,-2,-3) TBS

Date: 09-09-2018
Issue: A
Prepared for: Industry
Prepared by: Bill Davidson

12-14 Martin Drive
Tomago
02 4028 0400

Background:

It has been brought to the attention of Cougar IME that in some circumstances, maximum service brake pressures have been set higher than the maximum design pressure of 550kpa.

Transport Braking System registration MDR 095324 TBS defines the maximum pneumatic pressure setting of the service brake pressure applied system to be 550kpa or 33 bar hydraulic pressure where hydraulic gauges are installed.

This pressure setting is achieved via limiting the travel of the brake pedal via an adjustment bolt. In some cases, the limiting bolt and plate are not present or have been set to accommodate a larger travel than the design intended.

Communication:

Where full pressure or pressure greater than 550kpa (33 bar hydraulic pressure) is supplied, the decelerations induced via the service brakes may exceed 0.7g and pose a risk of overly aggressive braking.

Additionally, for the stored pressure system, a maximum pressure setting over 550kpa (33 bar hydraulic pressure) may not meet the requirement of MDG 39, section 1.4.8. Stored pressure systems

This clause requires that in the event of the engine failure or stoppage, 5 brake applications must be achievable.

Recommendations

1. Brake pedal service brake pressure should be inspected to review if it is set within the design parameters of the registration drawing MC49200 sheet 4.

Maximum service brake pressure setting: 550kpa (33 bar hydraulic pressure)
Minimum service brake pressure setting: 250kpa (15 Bar hydraulic Pressure)

2. Where not installed, fitment of a travel limiting plate HY00314S and adjustment bolt as depicted in **figure 1** is required at the next available service opportunity.

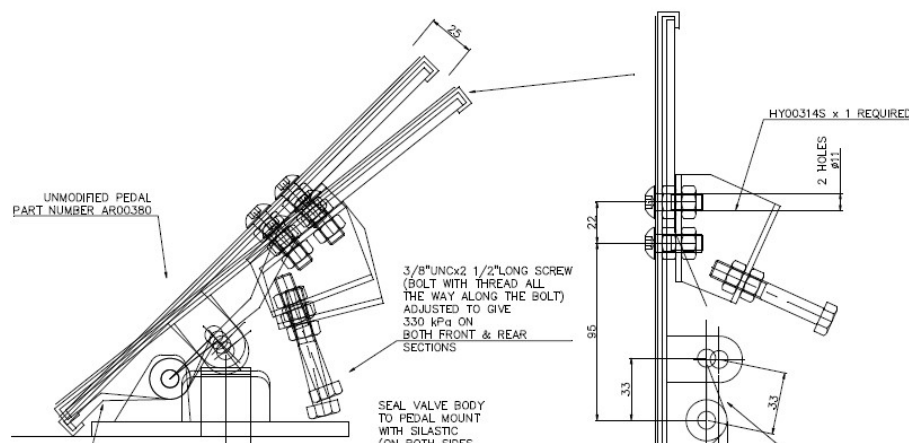

Figure 1: Brake Pedal limiting plate fitment and adjustment bolt

Please contact the below to make arrangements for this work.

Please distribute this bulletin to all relevant personnel

Cougar IME Contacts in respect to this bulletin:

Workshop Manager NSW	Garrad Latham	0407 272 296
Workshop Supervisor NSW	Dayle Tulip	0457 999 800
Workshop Manager QLD	Nick Gribble	0488 031 816
Parts Leader gregp@cougarime.com.au	Greg Piper	0409 995 278
Product Manager billd@cougarime.com.au	Bill Davidson	0409 562 385

References

1. *MDG 39: 'Handbook for Approval Assessment of Transport Braking Systems on Free-Steered Vehicles in Underground coal Mines'*
2. *MC49200 Sheet 4 BRAKE SYSTEM REGISTRATION DRG MK6 & MK7 MINECRUISER*